

GUZZLER[®]

Subsidiary of Federal Signal Corporation

Guzzcavator[™]



GUZZLER
GUZZLER MFG. INC.
STREATOR, IL
1-815-672-3171

GUZZLER!
GUZZLER MFG. INC.
STREATOR, IL
1-815-672-3171

GUZZLER
THE TOUGH YOU TRUST

GUZZCAVATOR™

100% Industrial Vacuum Loader. 100% Hydroexcavator.

THE INDUSTRY'S FIRST TRULY DUAL PURPOSE MACHINE.

Looking for a true multi-purpose industrial vacuum truck and hydroexcavator without compromising on performance? Look no further than the new Guzzcavator from Guzzler Manufacturing.

Guzzler Manufacturing, the industry's leader in industrial vacuum loaders, has been building and improving vacuum loaders for over 40 years. Today, industrial cleaning contractors are asked to do more with less. As a result, and with feedback from customers, Guzzler Manufacturing developed the Guzzcavator providing a no-sacrifice industrial loader and hydroexcavator in one powerful package. It combines the legendary Guzzler industrial vacuum performance and filtration and the powerful hydroexcavation capabilities of the Vactor HXX, making it the most versatile industrial contractor truck on the market.

This unique combination of features enable the Guzzcavator to handle a variety of applications, including standard wet/dry industrial cleaning, potholing, excavation services and oil and gas field support. The improved utilization and expanded versatility and productivity all add up to an improved bottom line.



CUSTOMIZED SOLUTIONS

The Guzzcavator design allows you to select a variety of options including a full opening rear door, a rear door mounted sludge pump for offloading, water heaters, and your choice of booms to meet specific needs so you get maximum productivity.

POWERFUL SUPPORT

FS Solutions serves as Federal Signal's authorized service and parts center for Guzzler. There are convenient facilities throughout North America providing genuine Guzzler OEM parts and factory-trained, certified technicians to service and repair Guzzler products, including blower repair on most makes and models.

UNMATCHED QUALITY

Guzzler products are painted prior to assembly with high quality polyurethane enamel, tested to ensure quality and proudly made in the U.S.A. The manufacturing facility in Streator, IL, which also produces Vactor® and TRUVAC® products uses processes certified to ISO 9001 and ISO 14001.

POWERFUL HYDROEXCAVATION

When high-flow hydroexcavation is required, the Guzzcavator blasts away soil with jets of up to 20 gallons of water per minute, at pressures up to 2,500 psi. Depending on the pump selection, variable water pressure adjustment and nozzle tip configuration, the truck's 1,300 gallon (4921 L) stainless steel water tank provides up to seven hours of continuous operation between refills. The Guzzcavator is also available with a 600 gallon (2271 L) water tank model to match alternate application needs.

WATER SYSTEM

The multi-flow pump allows water pressure adjustment with the push of a button for digging in various conditions. The water system is rated for flows up to 10 gpm @ 2500 psi, (20 gpm @ 2500 psi is also available). It is powered by a hydraulically operated triplex piston water pump. The water pump can be mounted in an optional heated cabinet for protection against cold weather conditions. Optional handguns and nozzles are available for various applications.

TELESCOPING BOOM

The telescoping boom provides robust lifting capacity. The pendant length reaches 55 ft (16.8 m) to give total access around the unit. The boom can be stored with the hose attached for greater convenience between locations and when transporting. An optional extendable boom is available.



1300 Gallon Tank



Water System Cabinet



600 Gallon Tank

EASE OF OPERATION

A wireless remote is standard and includes boom controls, full water pump control, vacuum enable/disable, and the standard emergency stop which brings the unit to a safe condition. Toggle switch controls are mounted in a single, fully sealed aluminum panel for easy monitoring including blower tachometer, E-Stop, blower temperature and hourmeter; hydraulic, vacuum and air pressure gauges. The wiring is harnessed, color-coded and each circuit clearly function stamped and individually grounded

ENHANCED OPERATOR ERGONOMICS

The operator has easy, safe access to the top of the Guzzcavator with a standard ladder, catwalk and railing. Baghouse and cyclone top inspection doors are accessed via the heavy-duty platform. Standard safety features include an E-Stop, body and rear door props, hydraulic check valves on all lift cylinders, back-up alarm and transfer case protection to prevent damage from shifting errors. An 8 in (203 mm), air-operated relief valve with wireless control, 4 in (102 mm) manual relief valve, and in-line, manual safety-T are also standard. The E-Stop cuts power to disable the vacuum and hydraulics and throttle the chassis engine down to idle.

EASE OF MAINTENANCE

The large baghouse and cyclone cleanout access doors simplify cleanup and maintenance. The efficient cyclone design provides access to the driveline components that require greasing. The boom hydraulic and electrical components are located at eye level. All filter components are 100% accessible.

ADVANCED REAR DOOR DESIGN

1/2 in (12.7 mm) steel-plate construction prevents deflection and warping. Tapered, locking, over-center chocks and three top-mounting brackets ensure a positive, leak-proof seal. A central hydraulic manifold provides a single access point for adjustments. Two double-acting, hydraulic cylinders (versus up to four on other brands) means less maintenance. Hinge blocks are shimmed to allow adjustment. The rear door seal raises with the door to remove the seal from the debris during dumping. A full-opening door is available as an option.

IMPROVED MODULE GROUNDING

For improved module grounding, the debris body, sub-frame and chassis are fully connected via a copper grounding strap, while an improved grounding cable clamp grounds the module components to their grounding location.

SUPERIOR DESIGN FROM THE WORLD'S LEADER IN VACUUM SOLUTIONS

ADVANCED FILTRATION PROCESS

Finding balance between filtration and productivity is what the Guzzcavator is about. Similar to the Guzzler CL industrial vacuum loader, the Guzzcavator's air-routing maintains the lowest pressure drop of any machine in its class, delivering the air where you need it.

SUPERIOR AIR ROUTING, FILTRATION

The 16-cubic-yard or 18-cubic-yard capacity Guzzcavator features a smooth, powerful vacuum source to quickly and efficiently recover material. The superior material separation in the debris body during vacuum operations consists of sixty 70" filter bags providing an air-to-cloth ratio of 9.94:1 for the lowest pressure drop in the industry. The linear wall connection from the cyclone to the baghouse has enough area to produce efficient airflow. The transition from the baghouse to the microstrainer includes an elbow and square to round transition for less disruption to the airflow as it moves through the system. The microstrainer and exhaust silencers are not directly mounted to prevent blower case distortion. A spring mounted subframe connection to the chassis prevents stress transfer through body and subframe.

The Guzzcavator's filtration system can be viewed in four stages:

FIRST STAGE

Debris Body

As vacuumed material enters the debris body, air speed slows. This allows gravity to remove the bulk of material.

SECOND STAGE

Cyclone Chamber

From the debris body, the air flows to the secondary pre-filter — the cyclone chamber — where centrifugal force hurls the denser particles to the cyclone wall and spirals them downward into the collection hopper. Material collected in this chamber is dumped simultaneously when the debris body is discharged. During hydroexcavation, this pre-filter serves as a highly efficient demister, extracting moisture from the airstream.

THIRD STAGE

Baghouse

The primary and secondary pre-filters remove 98% of all material from the airstream. All remaining particles are removed in the baghouse. Sixty 70" (1778 mm) Dacron filter bags deliver an air-to-cloth ratio of 9.94:1. Material collected in the baghouse hopper is dumped simultaneously with the main payload compartment.

FINAL STAGE

Strainer

Final vacuum pump protection is provided by the microstrainer. This is the safety drop-out point for any items that may have entered the system during servicing. A fine mesh screen prevents foreign objects from entering the blower.



OPTIONAL FEATURES



WATER HEATER

An optional 400,000 or 800,000 BTU/hr water heater is available to help cut through frozen ground and clay, and to aid in cleaning applications.



REAR DOOR MOUNTED SLUDGE PUMP

An optional rear-door mounted sludge pump with a 4 in (101.6 mm) removable, hydraulically driven pumphead is ideal for unloading sludges from the debris body and may be used during vacuuming.



FULL OPENING REAR DOOR

A full opening rear door allows for improved dumping by providing a greater area for material to pass. The optional door also provides the operator greater access and ability to clean the inside of the debris body.

ADDITIONAL OPTIONS: 20 GPM @ 2,500 PSI water system, cold weather package, air purge, extendable boom

ADDITIONAL SPECS:

BLOWER

- Positive displacement tri-lobe
- Max vacuum range: 27 Hg (0.93 kg/cm²)
- Max airflow range: 5,250 cfm (8,920 m³/hr)
- Customized ultra-quiet silencers

HYDRAULICS

- Hydraulic pump driven by PTO
- Hydraulic system plumbing assembled using JIC fittings and hydraulic tubing
- 50-gallon (189.25 L) hydraulic tank

DEBRIS BODY

- Payload capacity: 16 yd³ (12.23 m³) or 18 yd³ (16.45 m³)
- 1/4 in (16.35 mm) thick construction
- Rear bulkhead: 3/8 in (9.525 mm) thick plate with lower-edge reinforcement
- Rear door: 1/2 in (12.7 mm) thick, supported by three heavy-duty hinges
- Heavy-duty telescopic dump cylinder
- Liquid level float ball shut-off

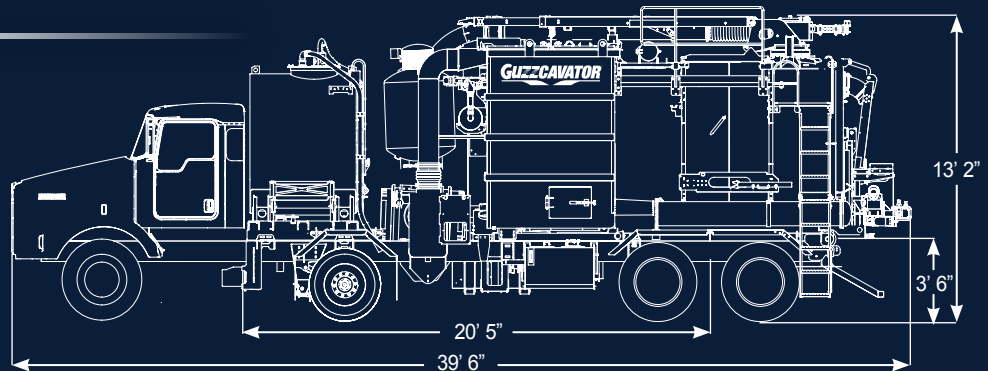

WATER SYSTEM

- 600 gallon (2271 L) or 1300 gallon (4921 L) water tank
- Rated at 10 gpm @ 2500 psi
- Hydraulically operated triplex piston water pump
- Handgun hose 3/8 in x 75 ft operating pressure of 3500 psi burst pressure of 14,500 psi

RELIEF VALVES

- 4 in (102 mm) manually-operated vacuum relief
- 8 in (203 mm) air-operated vacuum relief valve
- Inline tee vacuum relief valve

BAG CLEANING

- Baghouse is equipped with a 120 psi bag-cleaning pulsation system

DRIVE

- Air-shifted transfer case with manual override and shift protection

HYDRAULIC REAR DOOR

- Single-lever unlock/open and close/lock
- Bolt-on dump tubes
- Rear door and debris body props
- Roadside emergency kit and fire extinguisher

PROVEN PERFORMANCE IN: steel mills • oil refineries • chemical plants • natural disaster clean-up
 cement plants • oil & gas field service • metal mining • power plants • phosphate plants • railroads
 shipyards & docks • glass manufacturing • pulp & paper mills • grain elevators • material processing plants
 aluminum plants • lime & coal plants • bridge painting • waste-to-energy plants • foundries

YOUR PARTNER FOR THE LIFE OF THE MACHINE

Our relationship with customers goes beyond the delivery of a truck.

RIGHT START

The RightStart™ program has one goal, to improve customer satisfaction. It is designed to give you all the information you need to feel confident with your new equipment.

TRANSPORT

Upon the completion of your Guzzcavator, it is thoroughly tested. Once we've assured that everything is in top working order, we will contact you to make shipping arrangements. You may elect to come pick your new truck up from Streator, or have it delivered to your location.

TRAINING

Once you arrive or your truck is delivered, your training begins. An expert technician will guide you and your operators through all of the functions of your Guzzcavator, showing you how to safely operate the equipment for optimum results.

FOLLOW UP

Within 30 days and then again in 60 days, a Guzzler representative will call to see if you have any questions. Your complete satisfaction is our top priority.

SUPPORT

Of course, any time you have a question or require additional information, we are here to serve you. Just contact us at 1-800-627-3171 and get off to the right start.

Solutions™ Parts and Service Support

FS Solutions, a member of the Federal Signal Environmental Solutions group of brands, is the authorized parts and service center for Guzzler products. 11 locations are staffed with skilled, factory trained technicians and provide a range of product and services, with 5 specializing in hydroexcavation and industrial vacuum trucks.

- **High-performance parts** for most makes and models of industrial vacuum loaders, hydroexcavators and waterblasters.
- **Wide range of accessories** for industrial cleaning operations.
- **Repair and rebuild** vacuum trucks, pumps, blowers, and more.
- Large selection of **refurbished vacuum trucks and hydro excavators.**

Alabama

800.822.8785

8584 Borden Ave. SE
Leeds, AL 35094

California

866.515.9891

1510 Hayes Avenue
Long Beach, CA 90813

Texas

281.674.8668

10001 Porter Rd., #200
La Porte, TX 77571

New Jersey

732.448.7830

17 Jules Lane
New Brunswick, NJ 8901

North Dakota

701.572.7421

305 Energy Street
Williston, ND 58801

*Other locations featuring waterblasting rentals parts and service in Indiana, Louisiana, Ohio, South Carolina, and Washington

WARRANTY

The Guzzcavator is warranted against defects in material or workmanship for a period of 12 months from the delivery date of the original purchase. Optional extended warranty packages are available. Consult your Guzzler representative for complete warranty information.



www.guzzler.com



Guzzler Manufacturing, Inc.

1621 South Illinois Street

Streator, IL 61364 U.S.A.

(815) 672-3171 Phone • (815) 672-2779 Fax

Guzzler, Vactor, and Guzzcavator are registered marks of Guzzler Manufacturing, Inc. and Vactor Manufacturing. Specifications subject to change without notice. Some products shown with optional equipment. Federal Signal Corporation is listed in the NYSE by the symbol FSS. Guzzler is a subsidiary of Federal Signal Corporation. Effective Date 6/20 P/N 00044-B ©2020 Guzzler Manufacturing.