

PT MEDIUM DUTY LIFETIME WARRANTY MEGA-ROLLER™ w/ SELF-SECURING TONGUE-LOCK POLE TRAILER SPECIFICATION



**MEGA-ROLLER™ W/
SECURELOCK™ SYSTEM
(PATENT PENDING)**

LOWEST TOTAL COST OF OWNERSHIP (TCO) FROM:

- **LIFETIME WARRANTY MEGA-ROLLER™** (6 Roller Patent Pending) w/ Bronze Super Alloy Bearings Provides a Smooth “ONE MAN OPERATION” of the Tongue. NO TRUCK NEEDED to Extend or Retract. NO WEAR PADS TO MAINTAIN OR REPLACE.
- SELF-SECURING SECURELOCK™ Tongue-lock. No Pins to Lose.
- **PRACTICAL:** No Expensive, Unnecessary Bronze Components, yet we Don't Cut Corners and Provide Premium, Heavy Duty, Top-Quality Latches, Hardware, Fittings and Components.
- Non-Binding/Freezing EZ Slide Pole Centering Stanchions. Replaces Rusted/Seized Lever Lock Stanchions and Expensive Bronze.
- Heavy Duty yet Simple 5” H-Beam Pole Seats

BUILT FOR SAFETY. BUILT FOR SPEED. BUILT TO LAST.

CAPACITIES

- PT12: 13,800 lbs. GVWR @ 15% Tongue Weight
- PTL12: 13,800 lbs. GVWR @ 15% Tongue Weight
- PTL12-RE: 13,800 lbs. GVWR @ 15% Tongue Weight
- PT15: 17,250 lbs. GVWR @ 15% Tongue Weight
- PTL15: 17,250 lbs. GVWR @ 15% Tongue Weight
- PTL15-RE: 17,250 lbs. GVWR @ 15% Tongue Weight
- PT20: 23,000 lbs. GVWR @ 15% Tongue Weight
- PTL20-RE-15OH: 24,000 lbs. GVWR @ 20% Tongue Weight

AXLES

- PT12: 12K lbs. Sprung
- PTL12: 12K lbs. Sprung
- PTL12-RE: 12K lbs. Sprung
- PT15: 15K lbs. Sprung
- PTL15: 15K lbs. Sprung
- PTL15-RE: 15K lbs. Sprung
- PT20: 20K lbs. Sprung or Tandem 10K lbs. Sprung
- PTL20-RE-15OH: Tandem 10K lbs. Sprung

WHEELS

- PT12: (4) 16 x 6K / 8 on 6.5 BC w/ 5.50 Outset
- PTL12: (4) 16 x 6K / 8 on 6.5 BC w/ 5.50 Outset
- PTL12-RE: (4) 16 x 6K / 8 on 6.5 BC w/ 5.50 Outset
- PT15: (4) 17.5 x 6.75 HC / 8 on 275mm BC w/ 5.60 Outset
- PTL15: (4) 17.5 x 6.75 HC / 8 on 275mm BC w/ 5.60 Outset
- PTL15-RE: (4) 17.5 x 6.75 HC / 8 on 275mm BC w/ 5.60 Outset
- PT20 (20K Axle): (4) 17.5 x 6.75 HC / 8 on 275mm BC w/ 5.60 Outset
- PT20 (10K Axles): (8) 16 x 6K / 8 on 6.5 BC w/ 5.50 Outset
- PTL20-RE-15OH: (8) 16 x 6K / 8 on 6.5 BC w/ 5.50 Outset

TIRES

- PT12: (4) ST-235/85R16 LR-E Tires
- PTL12: (4) ST-235/85R16 LR-E Tires
- PTL12-RE: (4) ST-235/85R16 LR-E Tires
- PT15: (4) ST-215/75R17.5 LR-H Tires
- PTL15: (4) ST-215/75R17.5 LR-H Tires
- PTL15-RE: (4) ST-215/75R17.5 LR-H Tires
- PT20 (20K Axle): (4) ST-235/75R17.5 LR-H Tires
- PT20 (10K Axles): (8) ST-235/85R16 LR-E Tires
- PTL20-RE-15OH: (8) ST-235/85R16 LR-E Tires

BRAKES

- PT12: 12.25" x 5.00" Electric
- PTL12: 12.25" x 5.00" Electric
- PTL12-RE: 12.25" x 5.00" Electric
- PT15: 12.25" x 5.00" Electric
- PTL15: 12.25" x 5.00" Electric
- PTL15-RE: 12.25" x 5.00" Electric
- PT20 (20K Axle): 12.25" x 7.50" Air
- PT20 (10K Axles): 12.25" x 3.38" Electric
- PTL20-RE-15OH: 12.25" x 3.38" Electric

PAYLOAD: ALL FINAL PAYLOADS BASED ON CHOSEN MODEL AND OPTIONS

POLE WEIGHT (PAYLOAD)

- PT12: 10,050 lbs. Approx.
- PTL12: 9,500 lbs. Approx.
- PTL12-RE: 8,550 lbs. Approx.
- PT15: 13,400 lbs. Approx.
- PTL15: 12,850 lbs. Approx.
- PTL15-RE: 11,900 lbs. Approx.
- PT20 (20K Axle): 17,700 lbs. Approx.
- PT20 (10K Axles): 17,600 lbs. Approx.
- PTL20-RE-15OH: 18,150 lbs. Approx.

LENGTH

Retracted / Extended Lengths:

- PT12: 20' / 25' / 30'
- PTL12: 26' / 31' / 36' / 41'
- PTL12-RE: 27' / 32' / 37' / 42' / 50'
- PT15: 20' / 25' / 30'
- PTL15: 26' / 31' / 36' / 41'
- PTL15-RE: 27' / 32' / 37' / 42' / 50'
- PT20 (20K Axle): 30' / 35' / 40' / 45'
- PT20 (10K Axles): 26' / 30' / 36' / 40'
- PTL20-RE-15OH: 28' / 33.5' / 39' / 44.5' / 52.5'
- **Optional** Additional / Less Extension Increments Available

WIDTH: See Drawings Below

CURB WEIGHT:

- PT12: 3,750 lbs. Approx.
- PTL12: 4,300 lbs. Approx.
- PTL12-RE: 5,250 lbs. Approx.

CURB WEIGHT: (cont.)

- PT15: 3,850 lbs. Approx.
- PTL15: 4,400 lbs. Approx.
- PTL15-RE: 5,350 lbs. Approx.
- PT20 (20K Axle): 5,300 lbs. Approx.
- PT20 (10K Axles): 5,400 lbs. Approx.
- PTL20-RE-15OH: 5,850 lbs. Approx.

Actual Trailer Weight will Vary with Options & Finishes Chosen.

CARGO BED

- PT12: 85.5" X 43.75" (Customizable)
- PTL12: 136.25" X 43.75" (Customizable)
- PTL12-RE: 136" X 40" (Customizable)
- PT15: 85.5" X 43.75" (Customizable)
- PTL15: 136.25" X 43.75" (Customizable)
- PTL15-RE: 136" X 40" (Customizable)
- PT20 (20K Axle): 137.25" X 42" (Customizable)
- PT20 (10K Axles): 96" X 42" (Customizable)
- PTL20-RE-15OH: 137" X 40" (Customizable)

STANDARD FEATURES

- **LIFETIME WARRANTY MEGA-ROLLER 6-ROLLER** Telescoping Tongue (NO WEAR PADS TO REPLACE)
- **SELF-SECURING SECURELOCK™** Tongue Lock Roller System (No Loose Pin)
- **NON-BINDING/FREEZING EZ-SLIDE POLE-CENTERING STANCHIONS**
- Oil Bath Hubs (Greaseable Option All)
- Electric Brakes
- Wheel Chock Holders
- Adjustable Spring Pads
- Slipper Springs
- Reinforced Spring Hangers
- Wheel Chock Holders
- ALL Pole Rests: 5" H Beam
- Winch Binders w/ Ratcheting Breaker Bar (**BOA Crank Winch Optional**)

STANDARD TRAILER BODY

- 6" X 6" X 3/8" ("Square" for Max Equal Lateral and Vertical Strength) Male Extendable Tongue (Compare to Competition)
- 8" X 8" X 1/4" Wall Female Tongue Tube
- 7-Position Adjustable Hitch
- 3/8" X 36" GR70 Yellow Zinc Safety Chains with Hooks
- 1/2" Zinc Plated GR70 Safety Chains for Models Exceeding 18,000 lbs. GVWR
- Removable Male Extension Tongue

STANDARD TRAILER BODY (cont.)

- Standard Cargo Area
- 12,000 lbs. Static Front Jack w/ Spring Return
- Fenders: 1/8" Fabricated Diamond Plate

WIRING

- DOT / ICC-- FMVSS / CMVSS Approved LED ULTRA- HIGH VISIBILITY 180 DEGREE BULLET Marker and Clearance Lights
- LED Sealed Beam Rubber Mounted Stop, Turn, Tail and Marker Lights
- **Internal Cat Track** Protects Wiring (and air brakes if applicable)
- Removable Rear Access Door to Access Cat Track and Wiring
- Breakaway Kit with Absorbed Glass Mat (AGM) Battery
- 100% Sealed Heat-Shrunked Wiring Connections w/ Full Loom
- FULLY PROTECTED 7 or 6 Way Female Plug acts as Junction Box Recessed in FRAME RAIL. No Easily Damaged Plastic Junction Boxes

PAINT

- I.M.P.A.C.T Intense Metal pH Acid Surface Prep (Superior to sandblasting that can infuse metal w/ oil)
- Seams Caulked
- Rust Preventative 2-Part Epoxy Primer
- Two-Part Polyurethane Topcoats (2 topcoats)
- Standard Colors: White and CAT Yellow (Custom Available)

OPTIONS

- Full Width of Trailer 5" H-Beam Pole Seat ILO 60" Wide
- 10-Year Galvanized Structural Warranty (2-Year Painted)
- BOA Hand Operated Ratcheting Pole Strap Winch for SAFETY and Ultra Ease-of-use
- Air Brakes w/ ABS
- Lever Lock Stanchions
- Wiring Connections Soldered and Sealed w/ Heat Shrink Tubing
- Plug-and-Play Sealco Wiring Harness
- Wheel Chocks: Rubber or All Weather Galvanized Grip Strut
- Spare Tire and Mount
- Extension Intervals to Customer Spec
- Solar Charged Breakaway Kit
- Quick-Rotate Swivel Jack
- 16" Long 6-Bolt Hitch Extension (w/ 52" Safety Chains and Breakaway Cable Extension)
- 3" Lunette Eye
- All Stainless Steel Fasteners (1/2" and under)
- Anti-Skid / Anti-Glare Sand Paint on all Walking Surfaces
- Various Trailer Light Plugs (Customer Choice)

OPTIONS (cont.)

- Truck-Lite Lighting
- Lug Nut Indicators

OPTIONAL LIGHT BAR

- All TIG Welded Aluminum w/ Claw-Tooth for Superior Grip
- Contains (4) Four 4" Stop/Turn / Tail Rubber Mounted Sealed Beam LED Lights
- (3) Three Center ID Marker Lights
- (2) Two Side Marker Lights
- 7-Way REMOVABLE, DOUBLE ENDED NON-HARD WIRED Light Plug (to prevent yank-out damage and for easy maintenance) (7-Way ILO 4-Way is easier to source and more readily available for you)
- 35' Standard Electric Cable Length with a 7-Way Connector Plug

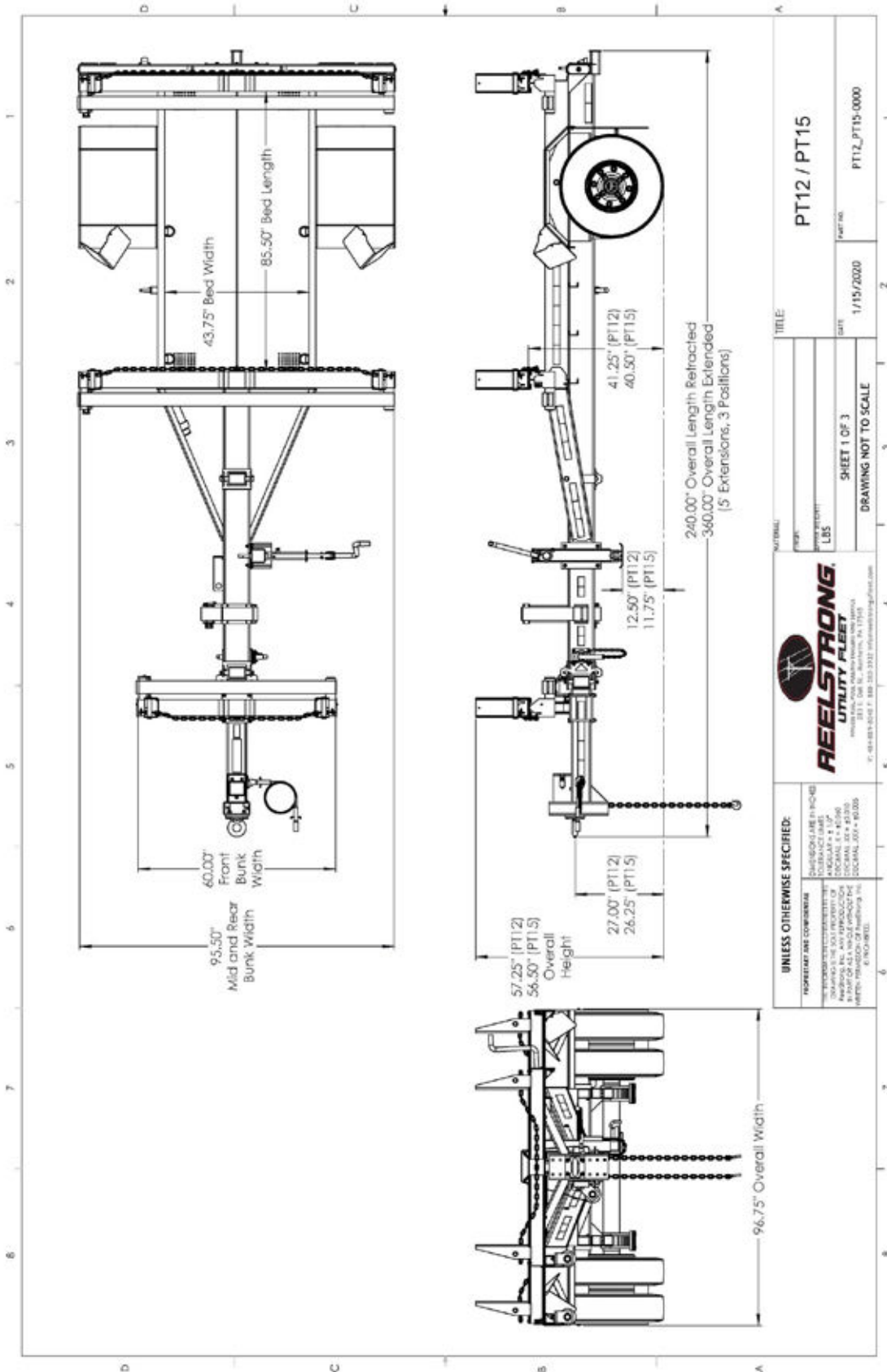

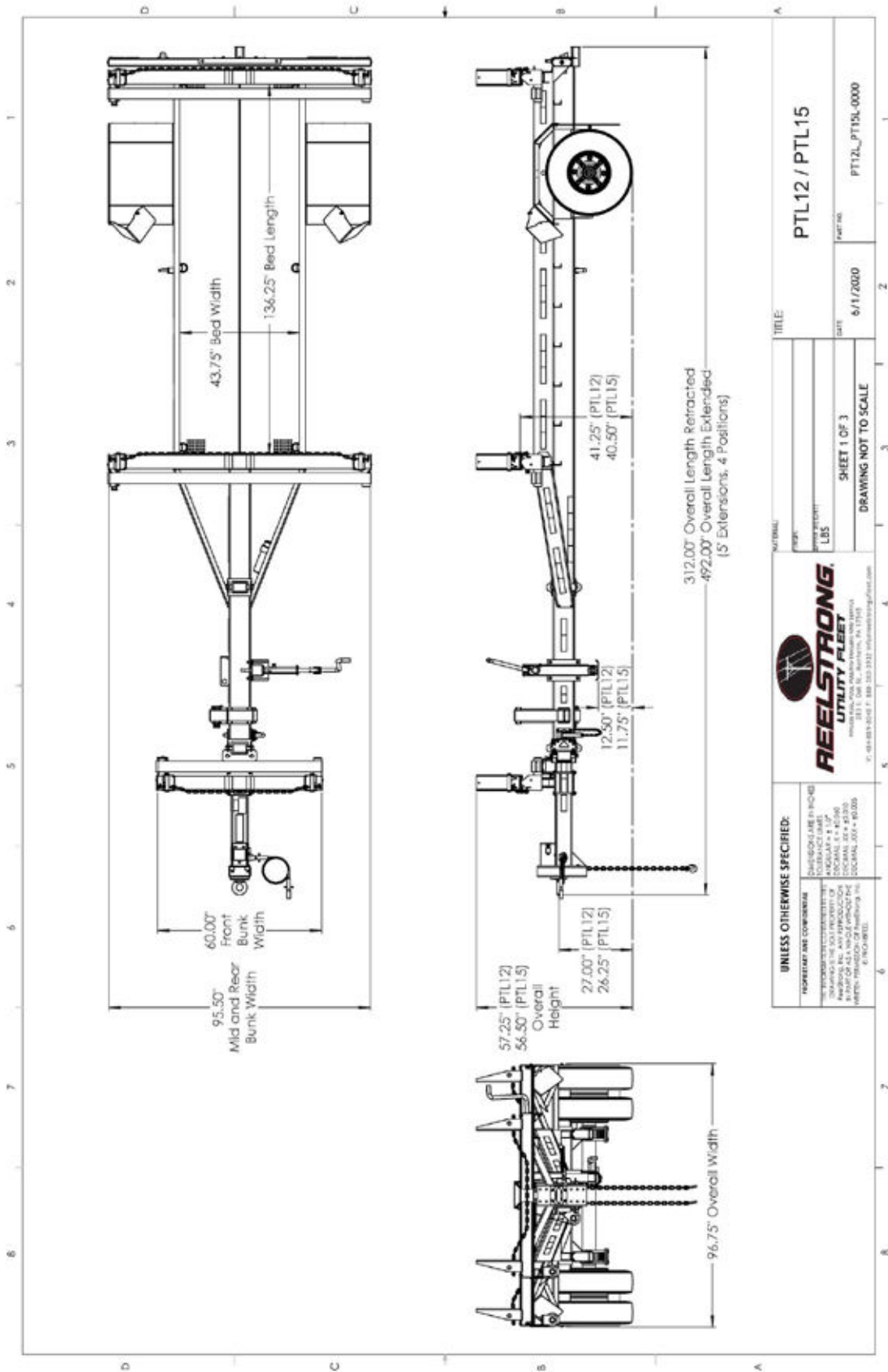

UNLESS OTHERWISE SPECIFIED: DIMENSIONS ARE IN INCHES TOLERANCES UNLESS OTHERWISE SPECIFIED: DIMENSIONS IN PARENTHESIS ARE DECIMAL INCHES DIMENSIONS IN SQUARE PARENTHESIS ARE DECIMAL INCHES DIMENSIONS IN BRACKET ARE DECIMAL INCHES DIMENSIONS IN ITALIC ARE DECIMAL INCHES DIMENSIONS IN BOLD ARE DECIMAL INCHES		 311 E. Oak St., Anderson, SC 29624 P: 803-585-4000 F: 803-533-3322 info@reelstrong.com	
MATERIAL:		TITLE: PTL12 / PTL15	
PART:		DATE: 6/1/2020	
WEIGHT (LBS):		SHEET 1 OF 3	
DRAWING NOT TO SCALE		PART NO: PTL12_PTL15L-0000	

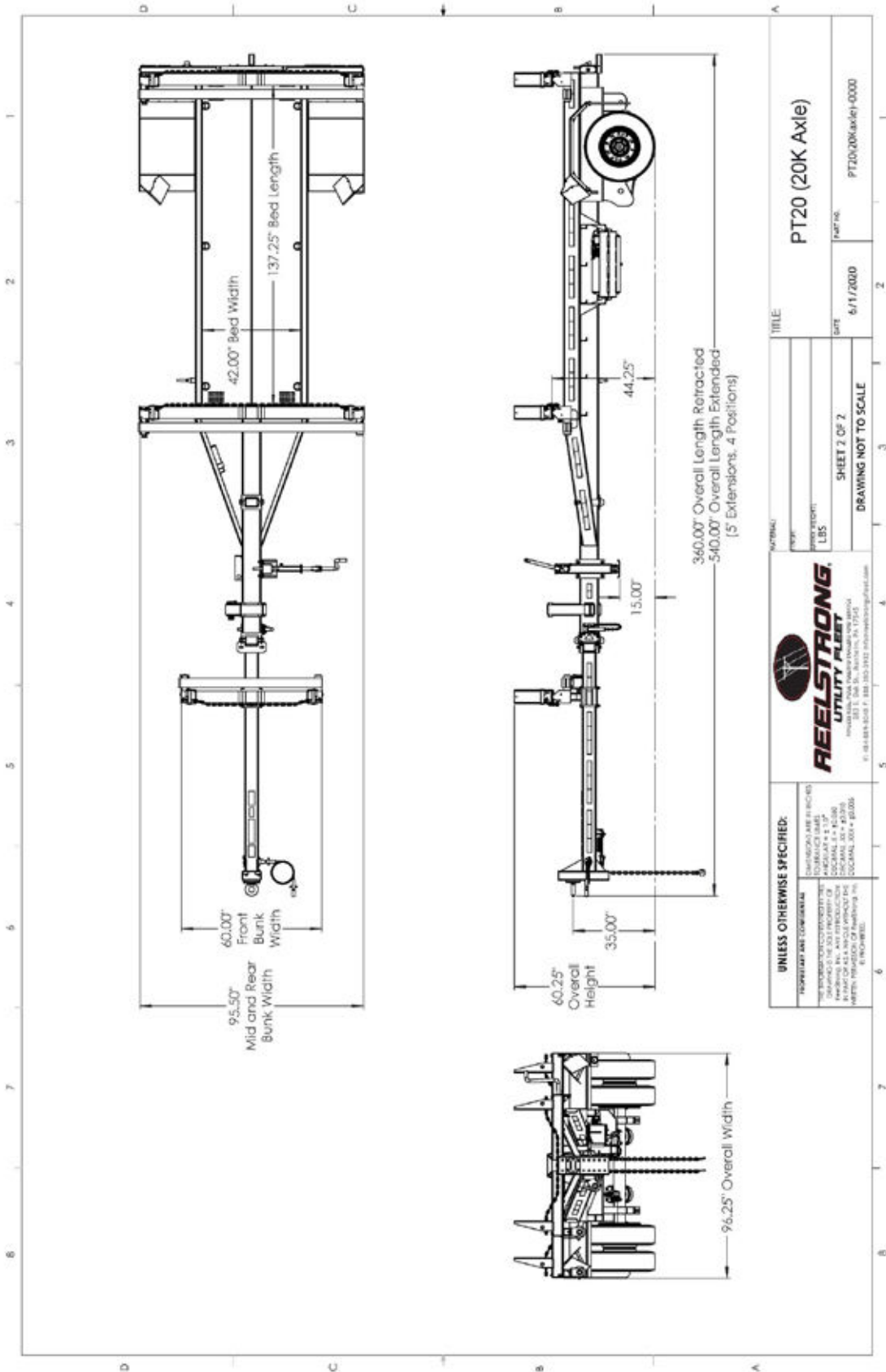

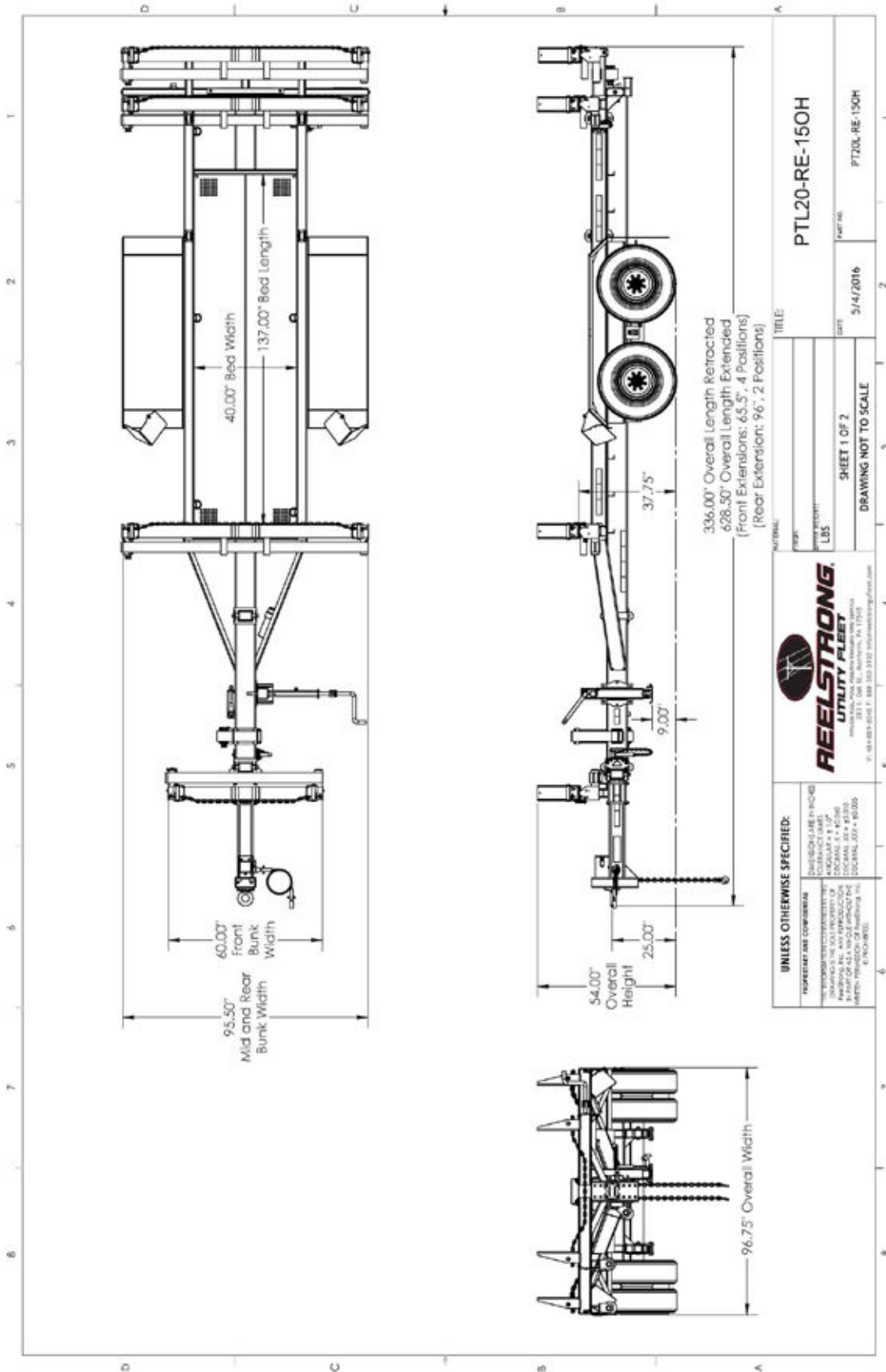

UNLESS OTHERWISE SPECIFIED: DIMENSIONS ARE IN INCHES TOLERANCES UNLESS OTHERWISE SPECIFIED: FRACTIONS: ±0.005 DECIMALS: ±0.010 ANGLES: ±0.5° HOLE POSITION: ±0.010 HOLE DIA: ±0.005 HOLE LOCATION: ±0.010 HOLE DIA: ±0.005 HOLE LOCATION: ±0.010		REELSTRONG UTILITY FLEET 10000 W. STATE ST. #1000 PHOENIX, AZ 85042 TEL: 480-983-1000 FAX: 480-983-1001 WWW.REELSTRONG.COM	
TITLE: PTL20-RE-150H		PART NO: P720L-RE-150H	
SHEET 1 OF 2		DATE: 5/4/2016	
DRAWING NOT TO SCALE			