

GR BLOCK LOCK™ GENERAL DUTY SELF-LOADING REEL TRAILER SPECS



EXCLUSIVE STANDARD ADDED VALUE:

- BLOCK LOCK™ Technology Provides Industry Leading Safety, Ease of Use, Low Maintenance, and Durability.
- SAFETY and Peace of Mind
- No Pins, Cotters, or Lanyards that Secure the Reel Arbor (which is the most critical safety point)
- Faster Reel Loading, Unloading, and Deployment Reduce Labor Costs and Fatigue on Workers.

BUILT FOR SAFETY. BUILT FOR SPEED. BUILT TO LAST.

CAPACITIES

- GR6K: 8,050 lbs. GVWR @ 15% Tongue Weight (available special order)
- GR8K: 11,050 lbs. GVWR @ 15% Tongue Weight
- GR10K: 13,800 lbs. GVWR @ 15% Tongue Weight

AXLES

- GR6K: 7K lbs. Axle
- GR8K: 10K lbs. Axle
- GR10K: 12K lbs. Axle

WHEELS

- GR6K: (2) 16 x 6K / 8 on 6.5 BC w/ Zeraset
- GR8K: (2) 17.5 x 6.75 HC / 8 on 6.5 BC w/ 0.19 Inset
- GR10K: (2) 17.5 x 6.75 HC / 8 on 6.5 BC w/ 0.19 Inset

TIRES

- GR6K: (2) 235/85R16 LR-E Tires
- GR8K: (2) 215/75R17.5 LR-H Tires
- GR10K: (2) 235/75R17.5 LR-H Tires

BRAKES

- GR6K: 12.25" x 3.38" Electric w/ Safety Breakaway Kit
- GR8K: 12.25" x 3.38" Electric w/ Safety Breakaway Kit
- GR10K: 12.25" x 5.00" Electric w/ Safety Breakaway Kit

PAYLOAD: ALL FINAL PAYLOADS BASED ON CHOSEN MODEL AND OPTIONS

REEL WEIGHT (PAYLOAD)

- GR6K: 6,000 lbs. Approx.
- GR8K: 8,500 lbs. Approx.
- GR10K: 10,000 lbs. Approx.

REEL DIAMETER: 125" Maximum

REEL OPENING

- GR6K: 66" Approx.
- GR8K: 64" Approx.
- GR10K: 60" Approx.

REEL SHAFT DIAMETER: 2.50" Solid w/ Centering Collars

—All specifications / designs are subject to change without notice - All GVWR and reel capacities are de-rateable to your needs.

OVERALL LENGTH:

- GR6K: 141.25" Approx.
- GR8K: 141.75" Approx.
- GR10K: 143" Approx.

OVERALL WIDTH: 102" Overall Width

OVERALL WEIGHT:

- GR6K: 1,950 lbs. Approx.
- GR8K: 2,200 lbs. Approx.
- GR10K: 2,300 lbs. Approx.

Actual Trailer Weight will Vary with Options & Finishes Chosen.

STANDARD FEATURES

- BLOCK LOCK™ Technology Provides Industry Leading Safety, Ease of Use, Low Maintenance, and Durability.
- Auto-locking Swing Out Reel Bar Retainer w/ Secondary Cylinder Lock
- Oil Bath Hubs (Greaseable Option All)
- Electric Brakes

STANDARD TRAILER BODY

- Heavy Duty 6" X 4" X 1/4" Frame
- 6-Position Adjustable Hitch
- 3/8" X 36" GR70 Yellow Zinc Safety Chains with Hooks
- 8,000 lbs. Static Front Jack

WIRING

- DOT / ICC Approved LED Lights and Conspicuity Reflective Tape
- FMVSS / CMVSS Standard 108 LED Lighting
- Sealed Beam, Rubber Mounted Stop, Turn, Tail and Marker Lights
- 100% Sealed Heat-Shrunked Wiring Connections w/ Full Loom
- Breakaway Kit with Absorbed Glass Mat (AGM) Battery

PAINT

- I.M.P.A.C.T Intense Metal pH Acid Cleaning Technology
- Hydrofluoric, Sulfuric, Phosphoric ACID Blend Cleaning Preparation (Re-used sandblasting material can impregnate metals with oil)
- Seams Caulked
- Rust Preventative 2-Part Epoxy Primer
- Standard Colors: Red, Black, White and CAT Yellow

—All specifications / designs are subject to change without notice - All GVWR and reel capacities are de-rateable to your needs.

OPTIONS

- 13 HP HONDA Engine Hydraulic Power Pack Comes STANDARD w/ ENGINE COVER, 15 Gallon Reservoir, Replaceable Oil Filter, Pressure Gauge and Solar Fade Resistant Plastic Control Placard. (Electric Start Optional)
- 10-Year Galvanized Structural Warranty (2-Year Painted)
- 16" Long 6-Bolt Hitch Extension (w/ 52" Safety Chains and Breakaway Cable Extension)
- 3" Lunette Eye
- Rotating Arbor Ground
- Wiring Connections Soldered and Sealed w/ Heat Shrink Tubing
- Plug-and-Play Sealco Wiring Harness
- Wheel Chocks: Rubber or All Weather Galvanized Grip Strut
- Spare Tire and Mount
- Solar Charged Breakaway Kit
- All Stainless Steel Fasteners (1/2" and under)
- 13 HP Honda Engine Hydraulic Power Unit
- Engine Cover
- 12V Electric over Hydraulic Power Option
- 9" Bronze Overspin Brake
- Truck-Lite Lighting
- Lug Nut Indicators

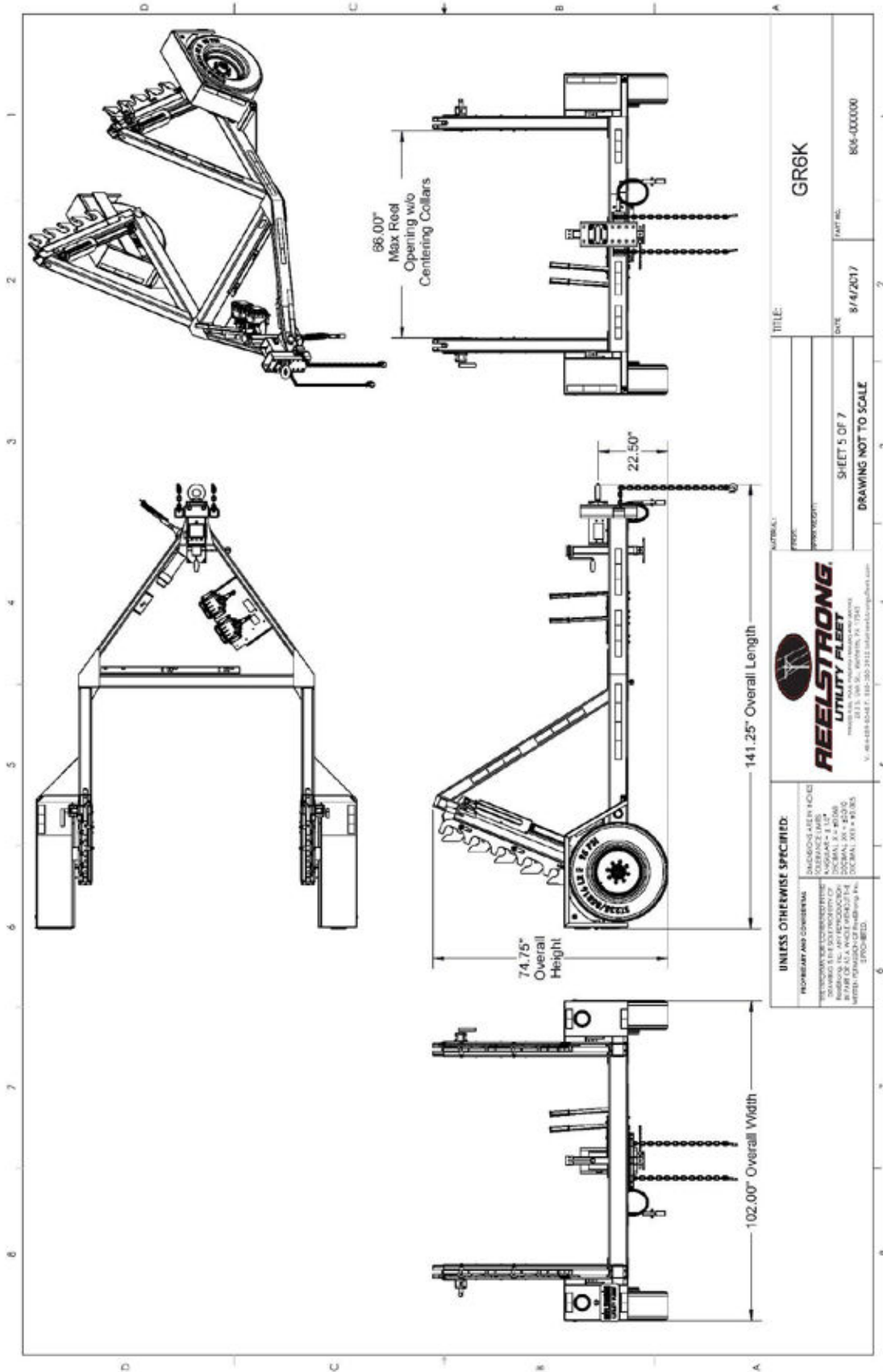

UNLESS OTHERWISE SPECIFIED: DIMENSIONS ARE IN INCHES TOLERANCES UNLESS OTHERWISE SPECIFIED: FRACTIONS .0005" - .0020" DECIMALS .0005" - .0020"		TITLE: GR6K
REELSTRONG UTILITY FLEET 1333 S. 300 St., Gulf Breeze, FL 32561 P. 904-439-6242 F. 904-439-6243		DATE: 8/4/2017
SHEET 5 OF 7		PART NO.: 806-000000
DRAWING NOT TO SCALE		

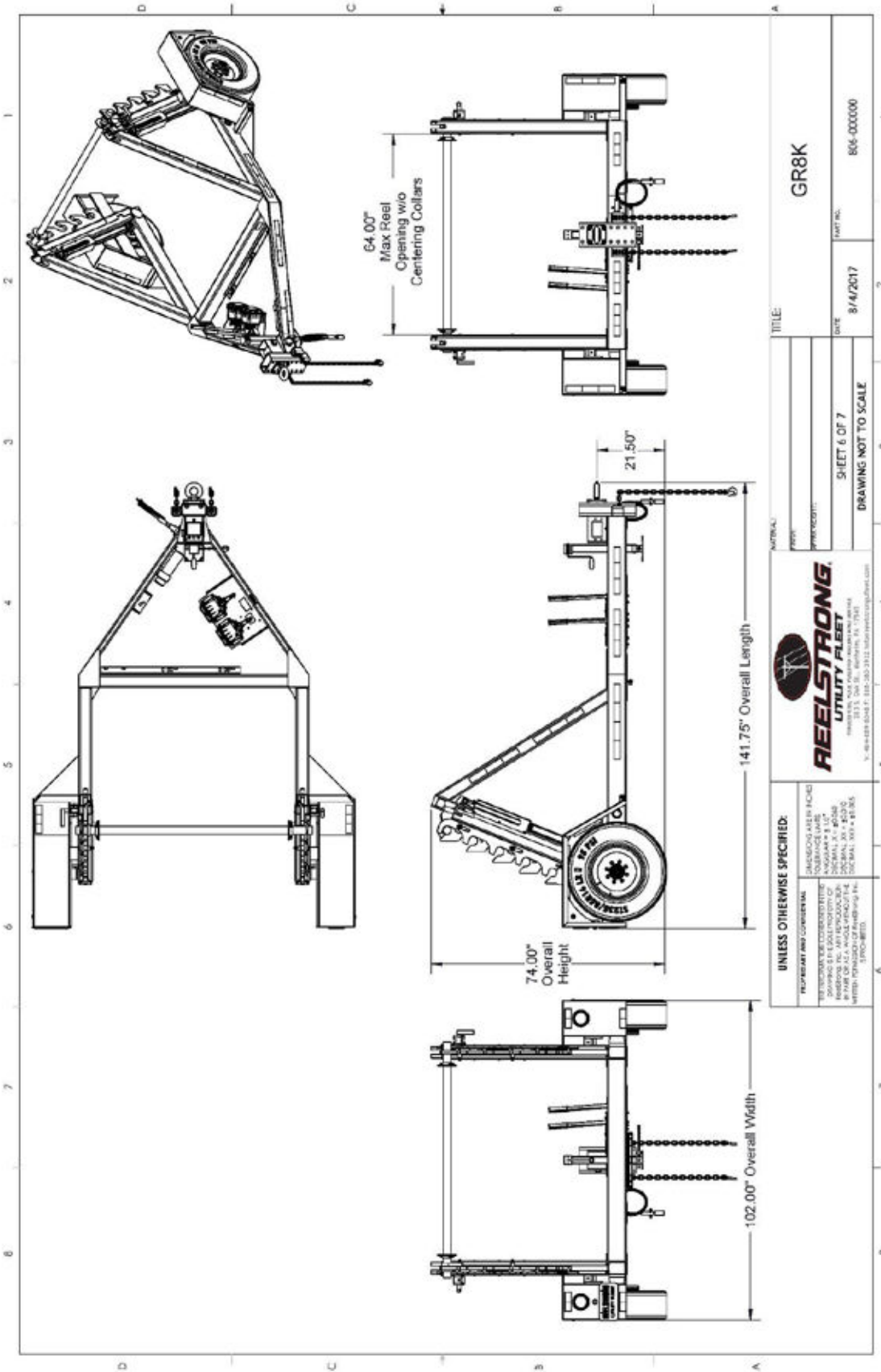

<p>UNLESS OTHERWISE SPECIFIED:</p> <p>PROFIT AND COMMERCIAL DIMENSIONS ARE IN INCHES TOLERANCES UNLESS OTHERWISE SPECIFIED: FINISHES: 1.0000" ± 0.0005" DIMENSIONS OF ALL ANGLES: PER AUTOMATIC CUTTING METHODS FOR THE MANUFACTURING OF STEEL PARTS</p>		<p>REELSTRONG UTILITY FLEET</p> <p>3113, Oak St., Baltimore, MD 21218 P: 410-528-2048 F: 410-528-2112 Email: reelstrong@jdc.com</p>	
<p>TITLE: GR8K</p>		<p>PART NO.: 806-000000</p>	
<p>SHEET 6 OF 7</p>		<p>DATE: 8/14/2017</p>	
<p>DRAWING NOT TO SCALE</p>			

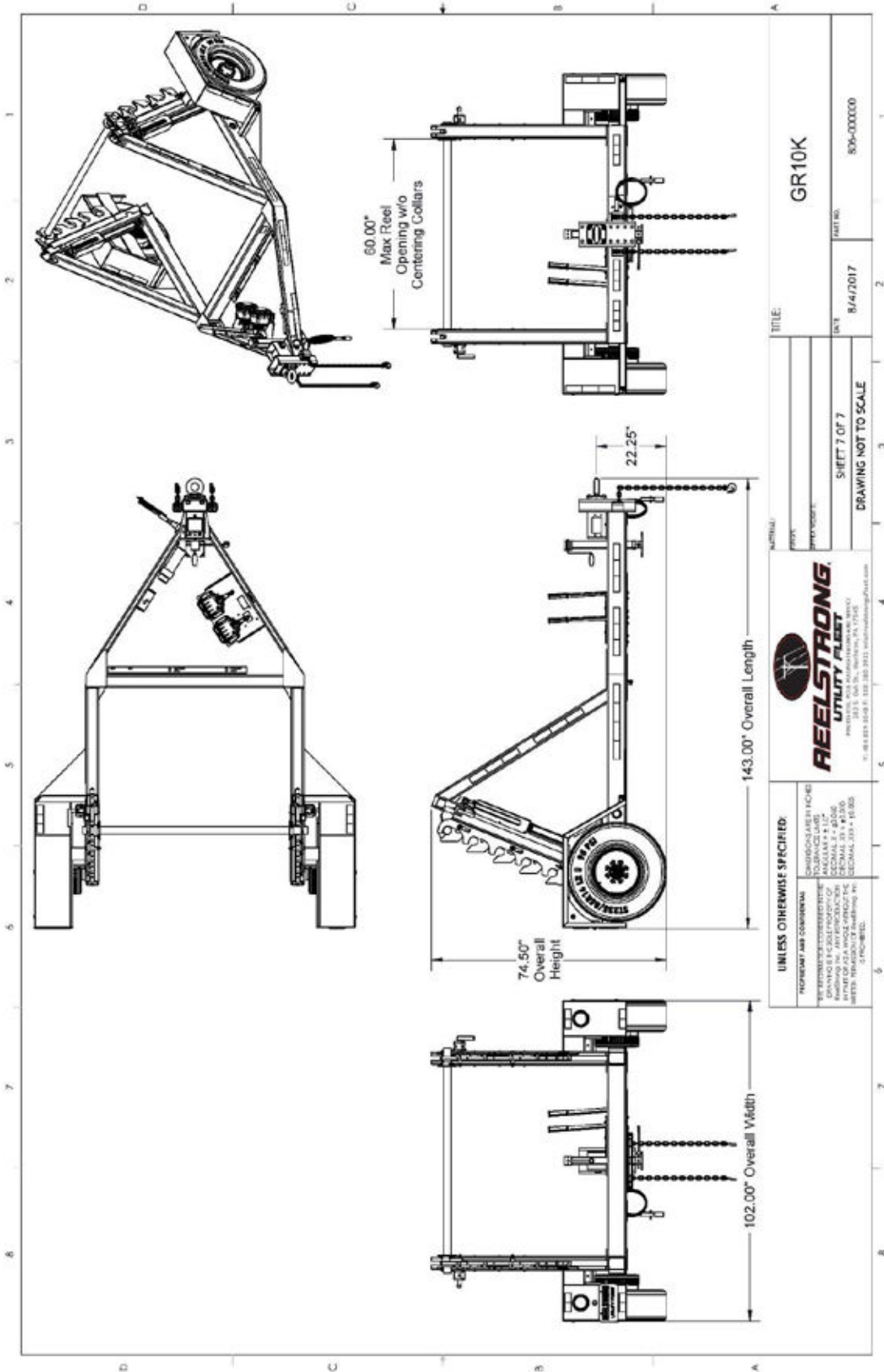

UNLESS OTHERWISE SPECIFIED: DIMENSIONS ARE IN INCHES AND DECIMALS THEREOF. DIMENSIONS IN PARENTHESES ARE FOR INFORMATION ONLY. DIMENSIONS IN PARENTHESES ARE FOR INFORMATION ONLY. DIMENSIONS IN PARENTHESES ARE FOR INFORMATION ONLY. DIMENSIONS IN PARENTHESES ARE FOR INFORMATION ONLY.		TITLE: GR10K DATE: 8/4/2017 SHEET 7 OF 7 DRAWING NOT TO SCALE	
REELSTRONG UTILITY PLUMB PHONE: 800-888-8888 FAX: 800-888-8888 WWW.REELSTRONG.COM		PART NO: 806-00000	