



KB-20 SERIES

BUILT WITH PRIDE IN THE USA

The KB-20 is well-known for its quality, economic efficiency, durability, and user-friendly design. With a variety of options for boom length and trailer capacity, this series is ideal for all types of loading applications. This unit can be tailored to fit your specific needs. DO IT RIGHT with Pac-Mac!

Awarded Contract
Contract # 041217-HMC

HGACBuy™
THE SMART PURCHASING SOLUTION

TECHNICAL DATA AND SPECIFICATIONS

GENERAL SPECIFICATIONS

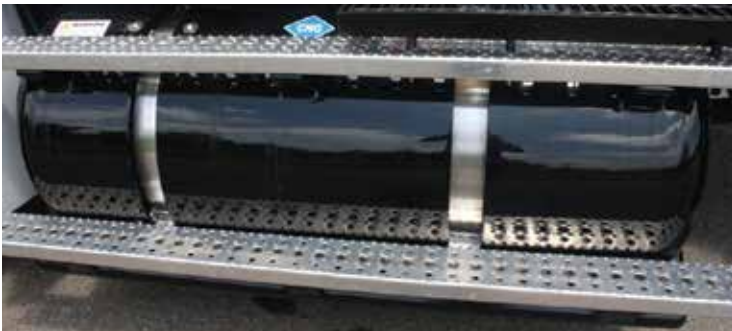
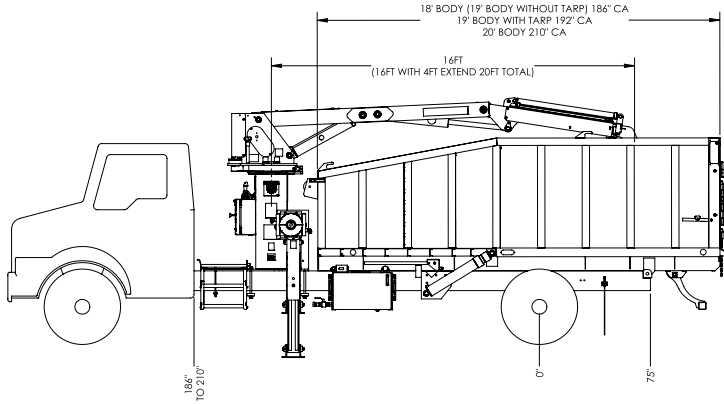

Pac-Mac can accommodate a variety of CNG tank options including saddle tanks below the rail or back of cab, above the rail

Height of boom to ground in lowest travel position (based on 37 in. chassis height)	11 ft.
Boom length	20 ft. (16 ft. with 4 ft. extension)
Optional boom lengths	16 / 17 / 18 ft. (fixed)
Boom rotation	270° non-continuous
Lifting capacity at 20 ft. (with bucket)	3,300 lbs. (standard) 4,500 lbs. (optional)
H-style outriggers	
Outrigger (extended)	11 ft. 8 in.
Outrigger (retracted)	8 ft.
Hydraulics	Tandem pump for simultaneous operation of multiple functions
Operator Controls:	
Standup	Individual levers or pilot-operated hydraulic joysticks
Rotating platform	Mechanical joysticks or pilot-operated hydraulic joysticks

RECOMMENDED CHASSIS

*Depends on loader configuration and options selected

Cab to axle (CA)	See Chassis Requirements
Front axle	12,000 lbs. (minimum) - single rear axle 14,000 lbs. (minimum) - tandem rear axle
Rear axle	21,000 lbs. (minimum) - single rear axle 40,000 lbs. (minimum) - tandem rear axle
GVW	33,000 lbs. (minimum) - single rear axle 54,000 lbs. (minimum) - tandem rear axle
Engine	250 HP (minimum)
Transmission	Automatic or manual
Frame	Minimum 1,500,000 RBM (150,000 PSI material)

BODY

Length	18 / 19 / 20 ft.
Capacity	20 / 24 / 25 / 30 cubic yds.
Tilt	45° +/- 1°
Floor	3/16 in. (1/4 in. optional) 8 in. main sill 4 in. joist with 12 in. spacing
Sides	Side ribs 24 in. spacing
Lighting	L.E.D. Mid-body turn signals (where applicable) Smart light

BUCKET

Width	4 ft.
Fully open	5 ft.

FEATURES

- Boom Height Alarm
- All hoses are enclosed within pedestal
- Pilot operated hydraulic joysticks
- H-style outrigger design
- Built-in holding valves for safety
- Smooth pads for minimal street damage
- Twin cylinders provide superior biting force (bucket)
- High strength tempered steel replaceable cutting edges (bucket)
- Anti-scalp design (bucket)
- 360 degree continuous rotation (bucket)
- Easy to use when handling heavy, bulky materials
- Complete discharge due to fully opening, swinging door(s)
- Bumper meets D.O.T. rear impact standards
- Twin telescopic dump cylinders
- 45 degree body tilt for complete cleanout
- Integral holding valves in main and tip boom cylinders for increased safety
- Ductile iron gland/piston, chrome rods, replaceable bronze bushings
- 1 year hydraulic warranty
- 3 year structural warranty
- 3 year warranty on gearbox and slewing ring

OPTIONS

- Hydraulic oil cooler
- Side arm hopper
- Door style options: single, barn, or scow
- Tarp options: spring assist with arm, spring assist armless, electric with arm
- Customer specific light location
- "Outrigger Up" safety feature
- Optional pneumatic air latch for rear door
- Body up alarm
- Nylon bearing outriggers