

# ELGIN®

Subsidiary of Federal Signal Corporation

## Broom Badger®



# THE BROOM BADGER

FROM ELGIN SWEEPER COMPANY



Looking for a maneuverable, powerful, compact mechanical sweeper? Consider the Broom Badger from Elgin Sweeper. This compact dual-engine sweeper is easy to operate and maintain, and does not require a CDL to operate, making it ideal for municipalities and contractors who need reliable, powerful cleaning without a full-size sweeper. The low-profile design uses best-in-class components, has reduced operating weight, and consumes less fuel than older equipment. The short wheelbase and tight turning radius give the operator great maneuverability for cul-de-sac curb lines and winding streets without sacrificing robust sweeping performance.



# EASY TO OPERATE. EASY TO MAINTAIN. NO CDL REQUIRED.



## ROBUST SIDE BROOMS

The Broom Badger features large dual side brooms with a maximum 9' 6" sweep path. The direct drive brooms are controlled in-cab for down pressure and tilt angle. The trailing arm design with spring kickback protects them from damage when sweeping close to obstacles. Four solid steel arms on each broom feature chromed shafts with composite greaseless bushings on all pivot points. These bushings reduce daily maintenance and have a long lifespan that results in lower overall operating costs.

## EFFICIENT MAIN BROOM

The 58" polypropylene main broom is hydraulically driven. The elevator is slightly wider for closer broom placement, providing more efficient material lifting and maximizing broom effectiveness. Self-aligning bearings for the broom mount and the free floating design ensure smooth movement over road surfaces. Simple adjustments for down pressure can be made to prevent broom coning.

## HEAVY DUTY SQUEEGEE ELEVATOR

The Broom Badger's 58.5" wide direct drive squeegee elevator handles heavy-duty sweeping applications. The innovative design eliminates the need for curtains and provides increased productivity. The open design and hinged plate enables easy cleaning and inspection. An in-cab alarm notifies the operator if an elevator stall occurs, then the rotation can then be reversed from inside the cab to dislodge the jammed debris.

## HYDRAULIC SYSTEM

The heart of the Broom Badger's hydraulic system is a variable displacement load-sensing piston pump that produces up to 32 GPM at 3,000 PSI. This style pump has lower fuel consumption and lower heat build-up across the entire hydraulic system. State-of-the-art hydraulic valves are used for each function and feature manual over-ride and flow adjustments for greater simplicity and reliability. In-cab electrical controls, external filter and restriction indicators, and low oil level shut-down are standard. All hydraulic valves are located in one ground level area for easy maintenance.



## OPTIONS

### ELEVATOR FLUSHER

The elevator flusher allows hydrant water flow to flood the squeegee elevator housing, reducing clean up time and effort.

### AIR SUSPENSION SYSTEM

The air suspension system, an Elgin exclusive on this size chassis, allows for a smooth ride, extended suspension capacity and rock-solid hopper dumping stability.

# SUPERIOR MECHANICAL SWEEPER DESIGN



## LARGE DEBRIS HOPPER

The side-dumping, 4 cubic yard debris hopper allows extended sweeping intervals for increased productivity on the job. The hopper is lifted by a single 4 stage cylinder lift with 9,400 lb lift capacity. A full payload can be off-loaded from the side dump hopper at ground level or at dump heights up to 10 feet.



## EFFICIENT PM-10 COMPLIANT DUST SUPPRESSION SYSTEM

The sweeper is equipped with a 220 gallon polyethylene water tank for dust suppression. Water nozzles are carefully positioned to suppress dust while sweeping.

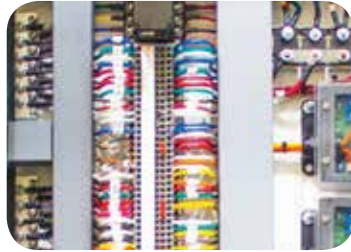

## ELECTRICAL SYSTEM

The Broom Badger's simple electrical system has been carefully designed to be extremely easy to navigate. It is hard wired with no controllers and electrical controls are sealed in a weather-proof systems locker. Wires are color and number coded for easy maintenance and trouble shooting.

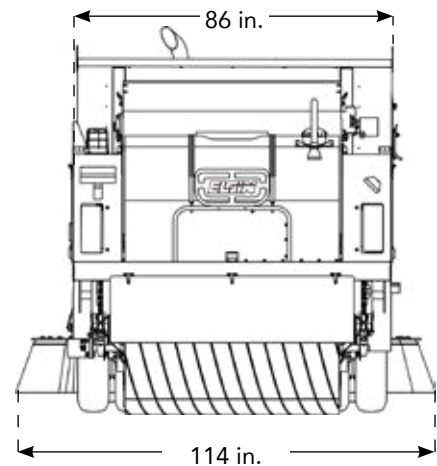
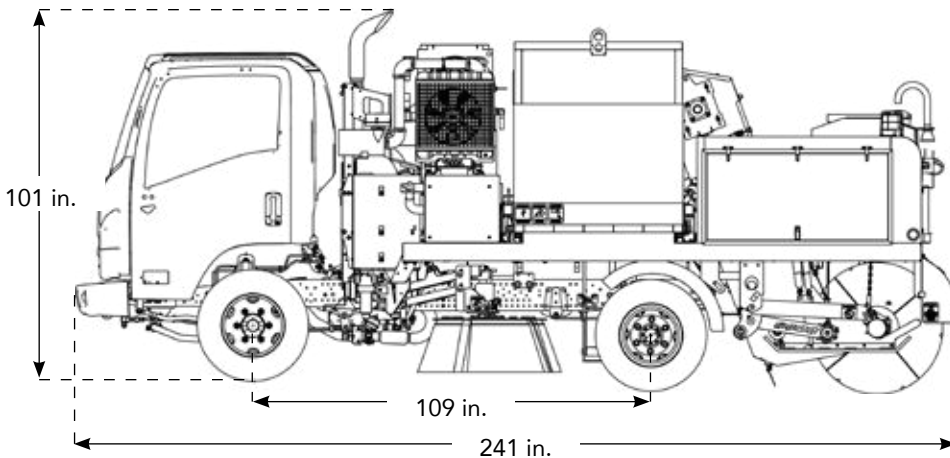

## SPECIFICATIONS

### SWEEP PATH

- Main Broom Only: 58" (1473 mm)
- Main Broom & One Side Broom: 87" (2210 mm)
- Main Broom & Two Side Brooms: 114" (2896 mm)

### MAIN BROOM

- Diameter 36" (914 mm)
- Length 58" (1473 mm)

### SIDE BROOM

- Streetside Diameter: 36" (914 mm)
- Curbside Diameter: 42" (1067 mm)

### CONVEYOR

- Squeegee with rubber edging

### HOPPER

- Volumetric Capacity: 4 cu. yds (3.02 m<sup>3</sup>)

### WATER SPRAY SYSTEM

- Tank Capacity: 220 gal (833 L)
- PM-10 compliant



### HIGH PRODUCTIVITY SWEEP SYSTEM

- Efficient Kubota 65.1 HP T4 Final engine
- Variable displacement piston type hydraulic pump producing 32 GPM
- Easy access to all components
- Only 6 grease points on sweeper body
- All pivot points feature chromed shafts with greaseless, long life bushings

### COMFORTABLE CHASSIS AND CAB

The Broom Badger is mounted on a 19,500 lb. GVWR Isuzu NRR Class 5 cabover chassis with optional air ride suspension for operator comfort and highway travel speed for quick transport from job to job. The cabover design provides excellent visibility for safer operation and has a short 109" wheelbase and tight 16'9" turning radius for exceptional maneuverability. Spot mirrors and low-cut windows enable precise gutter broom viewing. A standard dual-camera and 7" color monitor system provide views of the side broom or rear view for increased safety when sweeping.

An ergonomic control console ensures easy, comfortable operation. Simple rocker switches allow "one button" operation for quick sweep/transport mode changes.



# ELGIN SWEEPER IS YOUR PARTNER...

## IN THE PLANNING

Instead of one-size-fits-all solutions, we'll work with you to select the sweeping technology that fits your specific needs.



## IN THE STREETS

We're here to help you maintain your Elgin and train your operators to ensure the job is done right.



## INTO THE FUTURE

Our dealers don't just sell you an Elgin; they're available to answer your questions and provide service for the life of the machine.



## WARRANTY

Elgin Sweeper Company backs the Broom Badger sweeper with a one-year limited warranty. The Broom Badger is warranted against defects in material or workmanship for a period of 12 months from the date of delivery to the original purchaser. Optional extended warranty packages are available. Consult your Elgin dealer for complete warranty information.

Your Local Elgin Dealer Is:



[elginsweeper.com](http://elginsweeper.com)

1300 W. Bartlett Road • Elgin, IL 60120 U.S.A.

(847) 741-5370 Phone • (847) 742-3035 Fax

Specifications subject to change without notice. Some items shown may be optional. Elgin® Broom Badger® and Memory Sweep™ are registered trademarks of Federal Signal Corporation. Federal Signal Corporation is listed on the NYSE by the symbol FSS.

©2019 Elgin Sweeper Company. Effective 06/19 P/N 0705391-D